

25% OFF ALL SUBSCRIPTIONS! LIMITED TIME ONLY!



SOLAR ▶ WIND ▶ HYDRO ▶ DESIGN ▶ BUILD

GO! ADVANCED

[Home](#) » [Solar Hot Water Basics](#)

[My Account](#) | [View Cart](#)

Solar Hot Water Basics

ONLINE MEMBERSHIP

Email:

Password: [forgot it?]

Remember me?
 Yes No

LOGIN JOIN

By John Patterson

While most people are captivated by the high-tech nature of solar-electric (photovoltaic; PV) systems, in most cases, a solar hot water system will harvest more energy at a substantially lower cost. In fact, compared to PVs, solar hot water (SHW) collectors are more than three times as efficient at producing energy from the sun.

Investing in an SHW system is a smart solar solution for most homeowners. This proven and reliable technology offers long-term performance with low maintenance. And with federal, state, and utility incentives available, these systems offer a quick payback—in some cases, only four to eight years.

A thoughtfully designed SHW system could provide all, or at least a significant amount, of your household hot water needs for some portion of the year. The California Energy Commission estimates that installing an SHW system in a typical household using electric water heating can shave 60 to 70 percent off water heating costs. To get the most for your money, you'll want a properly sized system that offers the best performance in your climate.

MAGAZINE PRINT EDITION

SUBSCRIBE | RENEW CURRENT ISSUE

Solar Hot Water System Types

[SAMPLE ISSUE](#)
[CONTACT US](#)

Five main types of solar water heating systems are sold today. These five are a distillation of dozens of types sold over the past 25 years. They are:

- Batch
- Thermosyphon
- Open-loop direct
- Pressurized glycol
- Closed-loop drainback

The proven winners are simple, reliable, and long lasting. Some systems are "open loop" (the domestic water itself is directly heated) and some are "closed loop" (a heat-transfer fluid is heated by the collector and the heat is passed on to the domestic hot water by means of a heat exchanger). Some systems are "active," using moving parts such as pumps and valves, and others are "passive," using no mechanical or moving parts.

There are many considerations in choosing the best system for a home, but the client and the situation will dictate the right system.

For instance, for a one- to two-person household in a temperate climate where hard freezes rarely occur, you might go with a batch heater, especially if the hot water will be used more at the end of the day rather than first thing in the morning. In a household with three or more people, where aesthetics and weight are not an issue, the thermosyphon system might fit the bill, especially if there's no room for an additional tank near the existing water heater.

The drainback system, a personal favorite here in the Northwest, requires continuous drop between the solar collector and the solar storage tank. If continuous fall is not possible, there's always the pressurized glycol system where piping can go up, down, over, and around without concern. Usually more than one option can work for any situation.

The number of people in the household will dictate how large the system will need to be, and which systems are even possible. Rebate and incentive programs may only qualify certain systems in a given area. Some systems

ON SALE

THE HOME POWER ARCHIVE ON DVD SECOND EDITION

GET \$20 OFF FOR A LIMITED TIME!

Attn. School Libraries
 Free subscriptions to Home Power for K-12 school libraries.
<http://redwoodalliance.org>

HOME POWER INSTALLERS DIRECTORY

are relatively easy to install for do-it-yourselfers, while others most laypeople shouldn't attempt. See the comparative chart showing features of the different system types. Make your choice, and enjoy using solar energy to heat your water!

| Characteristic | Open-Loop | | | | |
|--|-----------|--------------|--------|--------|-----------|
| | Batch | Thermosyphon | Direct | Glycol | Drainback |
| Low profile—unobtrusive in appearance | | | ✓ | ✓ | ✓ |
| Lightweight | | | ✓ | ✓ | ✓ |
| Freeze tolerant | | | | ✓ | ✓ |
| Easy installation & infrequent service | ✓ | ✓ | ✓ | | |
| Passive operation—no pumps or controls | ✓ | ✓ | | | |
| Space saving—storage tank unnecessary | ✓ | ✓ | | | |

See also the following Home Power feature articles:

- [Sizing Solar Hot Water Systems](#)
- [Adventures in Solar Hot Water Efficiency](#)

Solar Batch Heaters

For a hundred years, simple solar batch heaters have been used in the United States. The term ICS (integrated collector storage) tells us that the collector and storage tank are combined into one unit. A tank of water, enclosed in an insulated box covered with glass, is placed in the sun facing south. Cold water is piped to the bottom of the tank; hot water is taken off the top. Whenever there's a call for hot water, water pressure from the home moves hot water from the top of the solar batch heater as cold water is pushed into the bottom.

Since the potable water is heated directly, this is an open-loop system. And since no pump is used to move the water from collector to end use, it is passive. The batch heater is a popular choice for homes in moderate climates where freezing is not much of an issue. Commercially manufactured batch heaters are relatively low cost. Crude batch heaters can even be homemade. If batch heaters are installed on the roof, weight has to be taken into account. Commercial batch heaters can weigh 200 pounds (90 kg) dry, and when filled with 40 gallons (150 l) of water, more than 320 pounds (145 kg) is added.

Because of their relatively low cost and simplicity, for those living in moderate climates with good sunshine available, the batch heater is probably the best value for heating domestic water.

The following illustration includes the primary components of any solar batch heater system. See our [Solar Hot Water System Components](#) section for an introduction to the function(s) of each component.

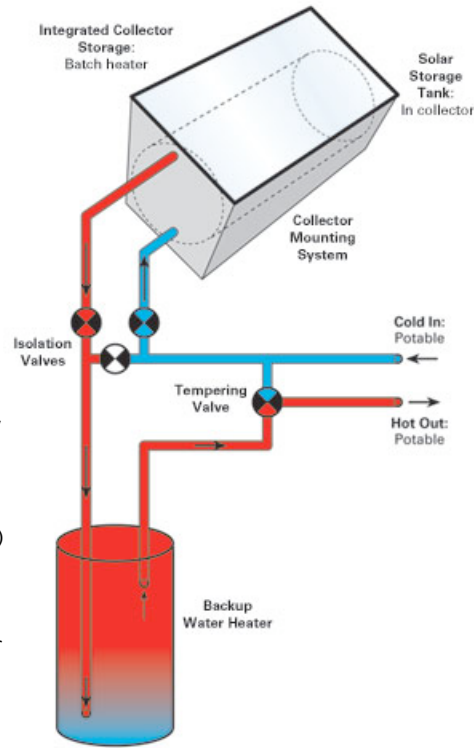

Thermosyphon Systems

Another relatively simple, passive system, and the most popular solar water heater worldwide is the thermosyphon. Common in Japan, Australia, India, and Israel, they are easily recognizable because the tank must be located directly above the collector.

Thermosyphon systems work on the principal of heat rising. In an open-loop system (for nonfreezing climates only), potable water enters the bottom of the collector and rises to the tank as it warms. In colder climates, an antifreeze solution, such as propylene glycol, is used in the closed solar loop, and freeze-tolerant piping, such as cross-linked polyethylene (PEX), is used for the potable water lines in the attic and on the roof.

Several international manufacturers make thermosyphon systems. The advantage of this system over the batch heater is that solar heat is stored in a well-insulated tank, so hot water can be used any time, without the penalty of overnight losses.

The following illustration includes the primary components of any thermosyphon system. See our [Solar Hot Water System Components](#) section for an introduction to the function(s) of each component.

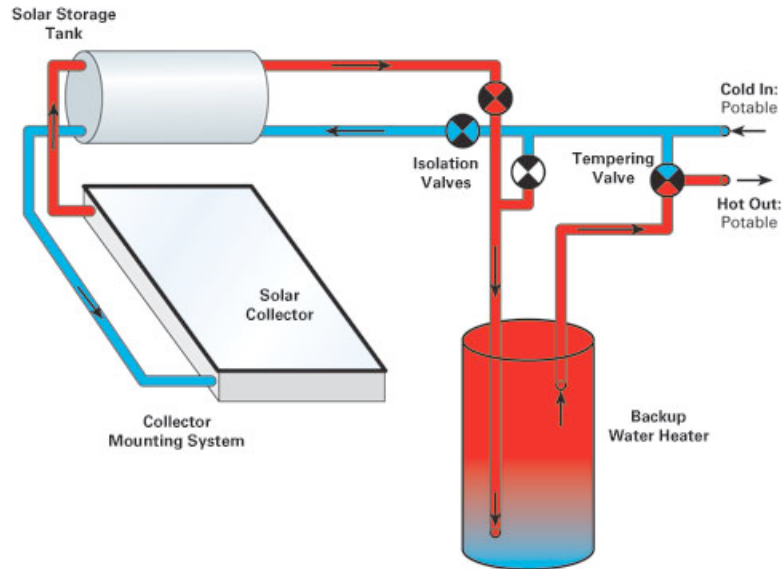

Open-Loop Direct Systems

Used in tropical settings where freezing never occurs, this is the simplest of the active systems. A standard, 52-gallon (200 l) electric tank can be used, teamed with a 40-square-foot (3.7 m²) solar thermal collector. Normally the electric element is not hooked up, so this tank becomes a storage tank only, for preheated water feeding an existing backup water heater.

An air vent, automatic or manual, is installed at the high point of the solar thermal collector to initially purge air. The pump, a small circulator pump using as little as 10 watts, can be powered directly by a 10-watt PV module, or a thermostatically controlled AC pump can be used. A snap-switch sensor can be installed to limit the temperature the solar tank reaches. Standard snap-switch sensors are available for 160°F or 180°F (71 or 82° C).

The following illustration includes the primary components of any open-loop direct system. See our [Solar Hot Water System Components](#) section for an introduction to the function(s) of each component.

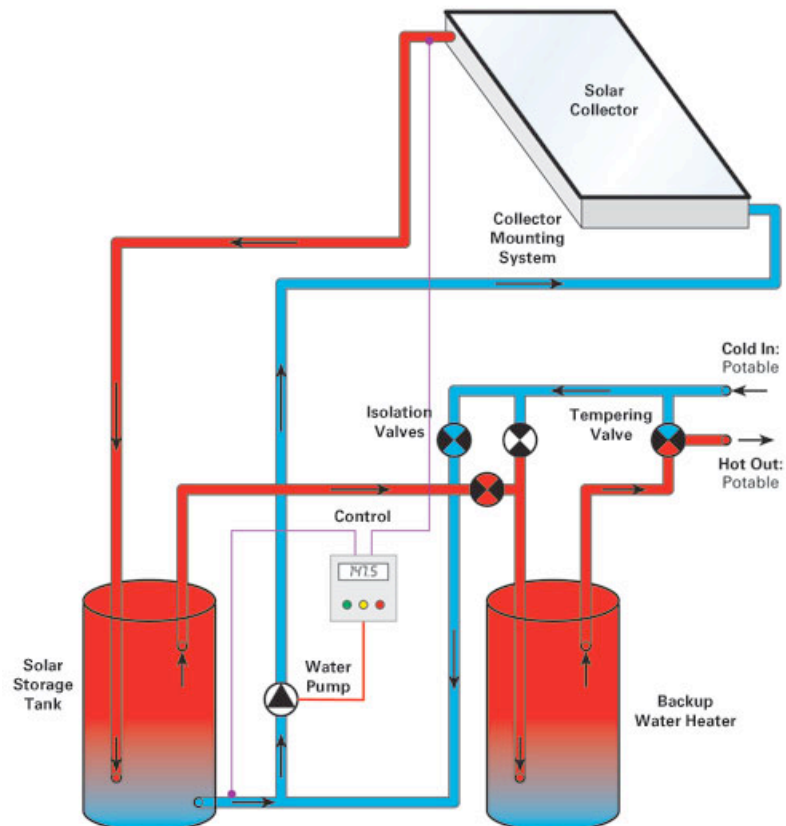

Pressurized Glycol Systems

In this active, closed-loop system, incoming potable water is routed to the solar storage tank, but never into the collectors. A water and antifreeze mixture circulates from the collectors through a coil of pipe in the solar tank, and then is pumped back through the collectors. (In most climates, a 50/50 propylene glycol and water mixture will keep collectors from freezing.) The potable water is warmed by heat transfer through contact with the pipe.

These systems require an expansion tank and a few other auxiliary components for filling, venting, and maintaining the system. A definite advantage to antifreeze systems is that the collectors can be mounted anywhere. These systems are pretty much the only choice in very cold climates.

The following illustration includes the primary components of any pressurized glycol system. See our [Solar Hot Water System Components](#) section for an introduction to the function(s) of each component.

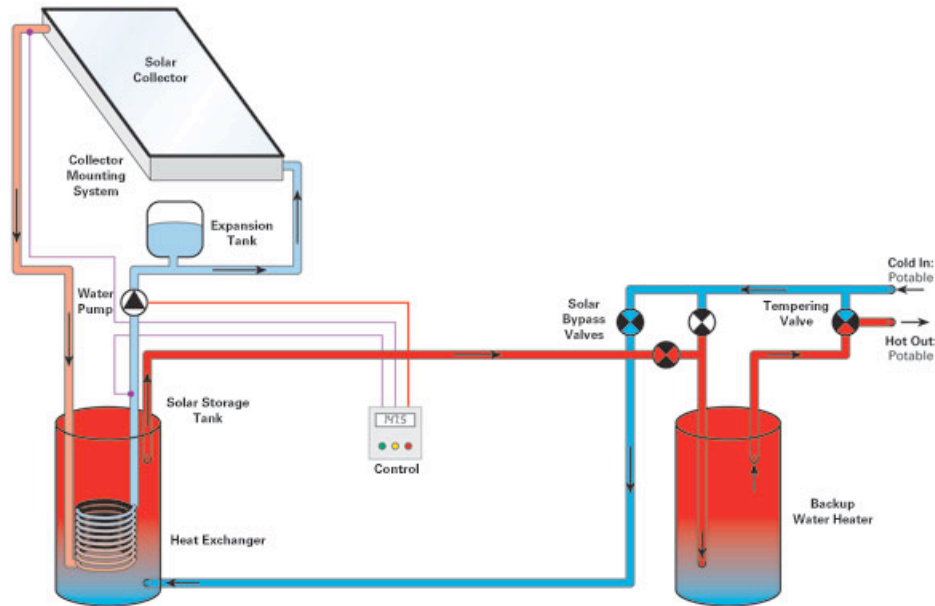

See also the following Home Power feature articles:

[Solar Hot Water for Cold Climates: Closed-Loop Antifreeze System Components](#)

Closed-Loop Drainback Systems

The closed-loop drainback system requires perhaps the least routine service of any active system. The heat-transfer fluid is distilled water, which seldom has to be changed. When the system is at rest (not pumping), the solar collector is empty and the distilled water is stored in a 10-gallon (38 l) reservoir tank, usually located just above the solar storage tank. Higher capacity reservoir tanks are typically required in large systems.

When the pump turns on, the distilled water is circulated from the reservoir back through the collector and heat exchanger, passing heat to the potable water in the solar tank. When the pump shuts off again, the distilled water drains back into the reservoir. The collector must therefore always be higher than the storage tank, and there must be sufficient continuous slope in the piping to ensure against freezing.

Drainback systems are effective and reliable. They work great, even on the hottest and coldest days of the year, and can operate twenty years without needing service. The only downside is that larger pumps usually have to be used, especially if you're pumping water two stories or more, since the drainback pump has to lift the distilled water to the height of the solar collectors.

One way around the height problem is to place the reservoir in the attic, reducing the height the pump has to lift. However, if it's located in a place where the pipes going to and from the reservoir could freeze, glycol must be added. This is also done when long, horizontal pipe runs do not allow drainback to occur quickly.

The following illustration includes the primary components of any closed-loop drainback system. See our [Solar Hot Water System Components](#) section for an introduction to the function(s) of each component.

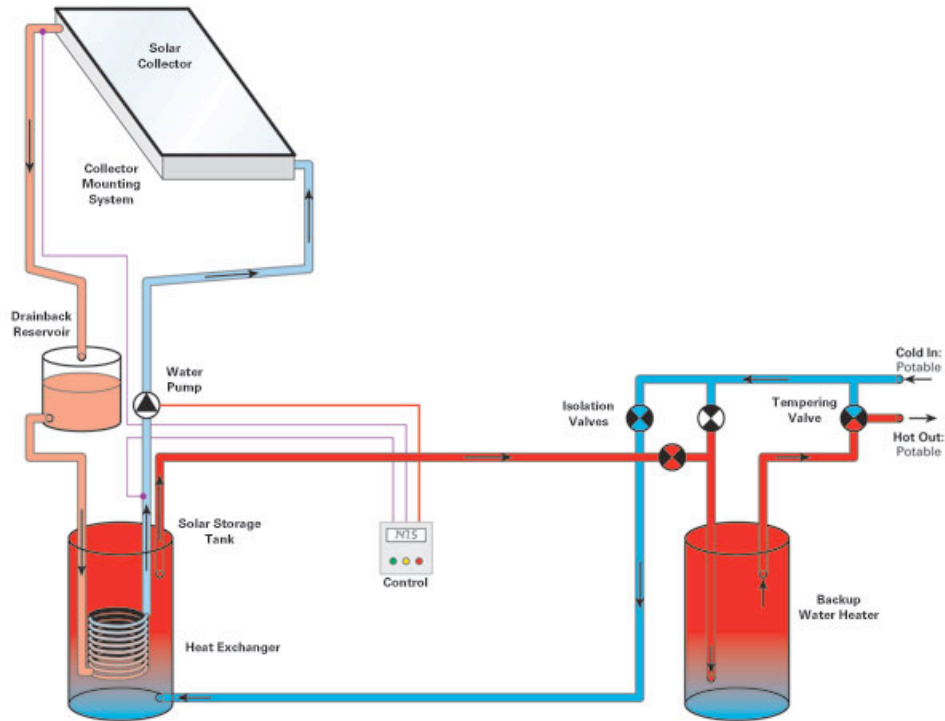

See also the following Home Power feature articles:

[Designing a PV-Powered Drainback Solar Hot Water System](#)
[SDHW Installation Basics—Part 3: Drainback System](#)
[Solar Hot Water for Cold Climates—Part 2: Drainback Systems](#)

Solar Hot Water System Components

Understanding the basic components of an RE system and how they function is not an overwhelming task. Here are some brief descriptions of the common equipment used in solar hot water systems. Systems vary— not all equipment is necessary for every system type.

[Solar Collectors](#)
[Collector Mounting System](#)
[Solar Storage Tank](#)
[Water Pump](#)
[Heat Exchanger](#)
[Expansion Tank](#)
[Controls](#)
[Isolation Valve](#)
[Backup Water Heater](#)
[Tempering Valve](#)

Solar Collectors

AKA: Solar thermal panels

A solar collector consists of a network of pipes through which water (or in colder climates, antifreeze) is heated. Collectors come in various sizes, with 4 by 8 feet (1.2 x 2.4 m) the most common.

On a typical summer day (sunny and warm), the fluid in the collectors reaches 140°F to 180°F (60°C-80°C). On a clear winter day (sunny and cold), it can reach 120°F to 150°F (50°C-65°C). When it's cloudy and warm, collectors can reach 70°F to 90°F (20°C-30°C), and when it's cloudy and cold, 50°F to 60°F (10°C-15°C). As long as the temperature in the collector is greater than that of your incoming cold water (usually about 50°F; 10°C), your solar hot water system is saving you energy.

Several types of solar collectors are on the market. Flat-plate are thin (3-4 in.; 7-10 cm), black, and covered with glass to hold in the sun's energy.

In evacuated tube collectors, a glass tube surrounds each individual pipe in a vacuum. This nearly eliminates the influence of ambient air temperature.

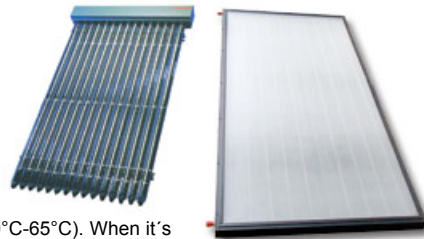

Evacuated tubes perform better than flat-plate collectors in cloudy weather, and can achieve higher temperatures compared to other collector types, but are typically more expensive. All active systems and some thermosyphon systems may use either flat plate collectors or evacuated tube collectors.



A third type, called integrated collector storage (ICS) or batch, combines the solar collector and storage tank into one unit. An ICS panel can resemble a flat-plate collector with greater depth (6 in.; 15 cm). A simple batch heater can be a tank within a glazed box.

Collector Mounting Systems

AKA: mounts, racks

The three most common mounting systems for solar collectors are the roof mount, ground mount, and awning mount. Roof-mounted collectors are held by brackets, usually parallel to and a few inches above the roof. Ground-mount systems can be as simple as four or more posts in the ground, lengths adjusted to affect optimal tilt. An awning mount attaches the collectors to a vertical wall. Horizontal supports push the bottoms of the collectors out to achieve the desired tilt.

When choosing a mounting system, roof mounts are usually the cheapest option, provided tilt and orientation are within acceptable parameters. If weight is an issue, ground mounts can be a good choice. Wall mounts are another solution that can work well in some situations.

Find the sunniest spot for your collectors. Generally, you want no shading between 9 AM and 3 PM. Facing collectors up to 30 degrees east or west of true south and at your site's latitude plus 15 degrees tilt, generally will still yield results within 15 percent of optimum. Any nominal losses from tilt, orientation, or even shading can usually be overcome by adding more collector area.

Solar Storage Tank

AKA: solar water tank, solar tank

A solar water tank is an insulated water storage tank. Cold water that used to go directly to your conventional water heater enters the solar tank and solar-heated water exits. In closed-loop systems, the water is heated by contact with a coil of pipe containing the water or antifreeze that circulates through the collectors. In open-loop systems, the potable water is directly circulated through the collectors.

The preheated solar water is then plumbed back to the cold side of your existing heater, which now functions as a backup. Whenever hot water is turned on in the house, preheated solar hot water is moved from the solar tank to the backup heater.

See also the following Home Power feature articles:

[New Life for Your Old Water Heater: Water Heater & Solar Tank Anode Rods](#)
[One-Tank SDHW Storage with Electric Backup](#)



Water Pump

AKA: circulating pump, circulator

Pumps are used in active systems, but are not required in batch or thermosyphon systems. They circulate water or antifreeze between the solar collector and the storage tank. The right pump for the job depends on the size of the system and the distance and height between the collector(s) and the storage tank. AC pumps plug into a wall outlet while DC pumps are powered from a DC source, such as a photovoltaic panel. Good pumps can last as long as 20 years with heavy use.

See also the following Home Power feature articles:

[Pick the Right Pump—Choosing a Circulator for Solar Hot Water Systems](#)



Heat Exchanger

Heat exchangers are used in closed-loop solar hot water systems. They enable the transfer of heat from one fluid to another without the two mixing. Internal heat exchangers are inside the tank and not visible. They can be as simple as a coil of pipe resting in the bottom of the tank, or wrapped around the outside beneath the insulation and cover. As the heated fluid from the solar collector travels through the coil, the heat is passed from the hotter fluid to the cooler potable water.

An external heat exchanger is usually a pipe within a pipe. The solar fluid and potable water flow counter to one another, and heat is transferred within the heat exchanger pipe. Fluid may be moved with pumps, thermosyphoning, or a combination of the two.

See also the following Home Power feature articles:



Heat Exchangers for Solar Water Heating

Homebrew Heat Exchanger

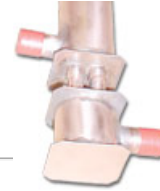

Expansion Tank

Closed-loop systems require an expansion tank. An expansion tank has a chamber in which air is locked inside a bladder or diaphragm. It screws into standard 1/2-inch or 3/4-inch threaded plumbing fittings. When pipes are filled with heat-transfer fluid (water and glycol) and the operating pressure of the system is set, the fluid will occupy a given volume based on the temperature. As the fluid is heated by the sun, it expands. This is where the expansion tank is critical. Without it, something would blow!



The expansion tank allows the fluid to safely expand by compressing the air in the chamber. The size of the expansion tank needed depends on the total volume of fluid, which is determined by the number and size of collectors, and the length and diameter of the pipes in the solar loop.

In most cases, a total of 3 to 6 gallons (11-23 l) of fluid is in a solar loop. A #15 (2 gal; 7.6 l) expansion tank is usually adequate. It never hurts to go larger, especially for systems with more than 60 square feet (5.6 m²) of collectors. A #30 has twice the expansion capability. With the proper expansion tank in place, the fluid can go from 0 to 200°F (-18-93°C) with the pressure in the solar loop remaining the same.

See also the following Home Power feature articles:

[What the Heck? Expansion Tank Sizing Expansion Tanks](#)

Controls

AKA: differential controls, PV module

In active systems using pumps, whenever the collector is hotter than the storage tank, the pump should be on and the system circulating. When the tank is hotter than the collector, the pump should be off. This function is performed by either a differential thermostat control system or the use of a PV-powered pump. The differential thermostat controller compares heat sensor readings from the storage tank and collectors and switches the pump accordingly.



With a PV-powered pump, a solar-electric panel is connected directly to the pump. It's a simple setup—when the sun comes out, the pump comes on. The brighter the sun, the faster it pumps. Controls are not needed in batch heater systems, where energy is moved by simple water pressure, or in thermosiphon systems, where energy is moved naturally by heat rising.

See also the following Home Power feature articles:

[What the Heck? Differential Control](#)
[Troubleshooting Solar Water Heating Systems—Part 1: Differential Controls](#)

Isolation Valve

AKA: solar bypass

An isolation valve should be a part of every solar water heater to isolate the solar tank in case of a problem, while still allowing the backup water heater to remain in service. The isolation valve is a manual valve or valves placed in both the incoming and outgoing potable water lines to the solar tank. It can be a three-valve configuration, or a three-port and two-port valve. Manually turning the valve or valves will place the solar tank "on line" or "off line." It works by directing the flow either through or past the solar tank. These valves can also be plumbed to bypass the backup gas or electric water heater, allowing them to be turned off (eliminating standby heat loss) during the seasons when the SHW system can supply 100 percent of the household's hot water.



Backup Water Heater

AKA: natural gas, propane, electric, or wood water heater

The backup water heater ensures that hot water is at the tap whether the sun shines or not. On a sunny, hot day, if the sun has preheated the water to 140°F (60°C) or more, the backup water heater uses no energy at all because the solar preheat temperature is greater than the typical 120°F (49°C) thermostat setting. On a day when the solar preheat is 85°F (29°C), the backup heater boosts the temperature the remaining 35°F (19°C). Since incoming cold-water temperatures are at ground temperature (usually about 50°F; 10°C), 85°F represents 50 percent of the energy



needed to bring the water from 50°F to 120°F.

Not all backup water heaters use a tank. Keeping a tank of water warm between uses can account for 15 percent or more of the total energy expended for hot water. Tankless water heaters eliminate this standby loss. Solar hot water systems and tankless water heaters are a winning combination. If you're in Seattle, for instance, and can reduce your water heating cost by 60 percent using solar energy, and save another 15 percent by going tankless, this results in a 75 percent total savings. The household that used to spend \$300 per year to heat water now only spends \$75. In sunnier climates, this number can approach zero. However, not all tankless heaters can be used as a backup heater for solar. Check with the manufacturer.

See also the following Home Power feature articles:

[Choosing a Tankless Water Heater](#)
[New Life for Your Old Water Heater: Water Heater & Solar Tank Anode Rods](#)
[One-Tank SDHW Storage with Electric Backup](#)



Tempering Valve

AKA: mixing valve

On a sunny day, the water in your collectors can reach scalding temperatures. A tempering valve can save you from a 160°F (70°C) shower. Ouch! The tempering valve goes at the very end of the chain, right after the backup water and before the faucet. If the water coming out of the backup heater is too hot, the tempering valve opens to mix cold water back in and prevent scalding. The temperature of the hot water can be set by the user on most valves. For instance, a popular valve allows a temperature setting between 120°F and 160°F (49°C-71°C).



[My Account](#) | [View Cart](#) | [Contact](#) | [Advertise](#) | [Terms of Use](#) | [Privacy Policy](#)

Copyright © 1987-2010 Home Power Inc. All rights reserved.